

The installations are CE certified, with a generous margin with regards to safety and hygiene. The basic line construction, minimises operational costs, more specifically in relation to consumption of water, energy and chemicals. A strong customer-oriented approach and a willingness to listen and to provide precision custom-made work is what makes Cretel NV an ideal partner for solving the more complex cleaning problems.



Applications

Multi-purpose crates (Euro-pool), commonly used in food industry, as its main feature is a returnable packaging, washing is of utmost importance.

Cretel machines guarantees the perfect washing features.



Features

- > Designed for minimal operation spaces and small plants.
- > Fully open and hygienic construction.
- > Rinsing water recuperation with return to the washing tank.
- > Easy cleanable static filter cartridge.
- > Chain transport system with variable speed.
- > Electrical heating thermostatically analog controlled



Options

Transport System:

Universal direction (Left or Right)

Exhaust System:

Fan with flow rate regulation valve to remove excess steam.

One Person Operation Looping:

To be loaded and unloaded per one operator.

Dosing System:

For the correct dosage of chemical products.

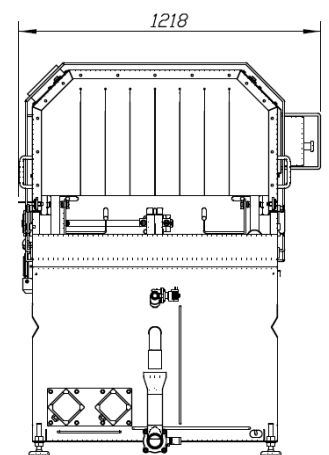
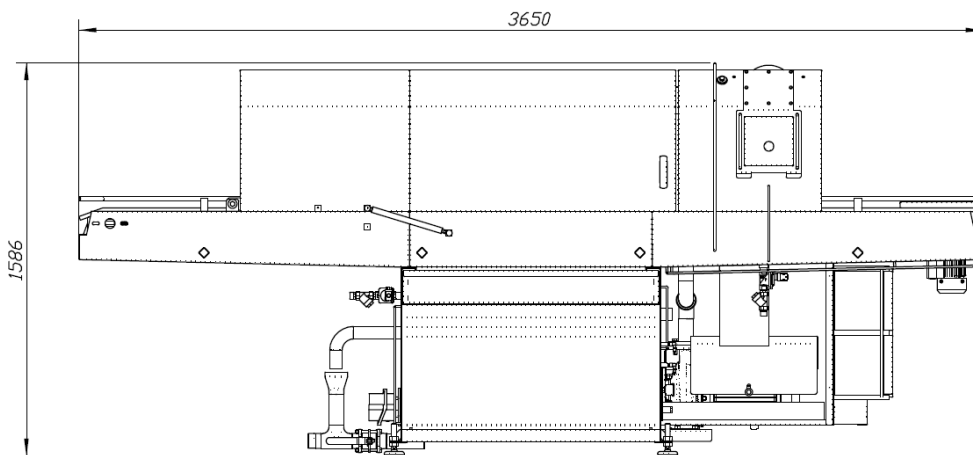

Model	Capacity (h)	Max. Gap (mm)	Cycles	Water Circulation Pump	Dimension (L x W x H) mm
AWM235.60	125 to 400	600 (W) x 300 (H)	Wash + Rinse	7.5 kW - 750 L/min - 3 Bar	3650 x 1218 x 1586

Remark: The nominal capacity is based on E2 crates with a contact time between 42 - 68 seconds.

CRETEL NV

Gentsesteenweg 77A

9900 Eeklo - Belgium



www.atsgroep.be

Tel: +32 9 376 95 95 Fax: +32 9 376 95 96

website: www.cretel.com

E-mail: info@cretel.com

AWM235.60/2017EN.V2—Alterations reserved.